



# AQUARIUS ENGINEERS PVT. LTD.

*Concrete Pumps, Batching Plants, Boom Pumps*



## TRAILER MOUNTED LINE PUMPS - 1410 D



### ▶ Salient Features:

- ▶ New futuristic look with latest design
- ▶ Completely redesigned with many operation friendly features
- ▶ Substantial noise reduction
- ▶ Maximum vertical/horizontal pumping distance in this class
- ▶ Reliable close loop Hydraulic System
- ▶ Very reliable equipment with long routine maintenance intervals
- ▶ Safe water-cleaning system
- ▶ Very effective reverse pumping
- ▶ Infinitely variable concrete output, from minimum to maximum
- ▶ Centralized greasing points
- ▶ Innovative flap straight design with cleaning socket
- ▶ Standardized core pump, reducing spares inventory costs
- ▶ Very effective and quick switch over of S-Valve

### ▶ Added Features:

- ▶ Higher Capacity jack
- ▶ Foot rest for hopper
- ▶ Gas springs and locks for canopy
- ▶ Shifting cylinder cover for better safety
- ▶ Grill provided for engine cover
- ▶ Built-in toolbox
- ▶ Efficient splash guard design
- ▶ Engine & Pump hour meters
- ▶ Remote control



Worldwide Preferred  
'S' Valve Technology

## Technical Specifications:

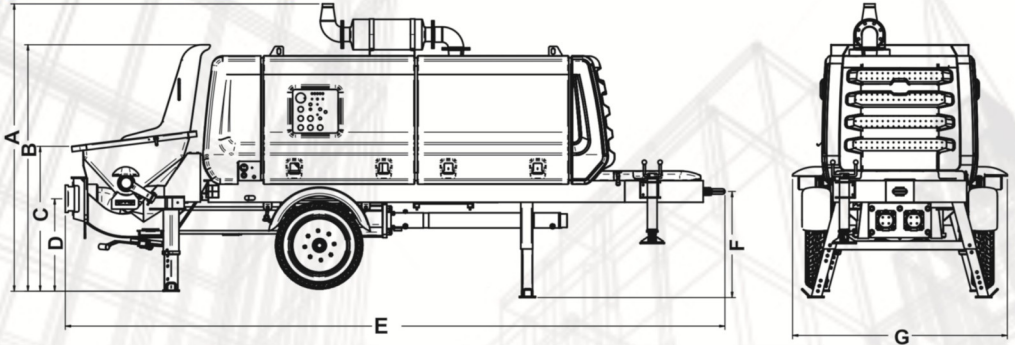

MODEL	A	B	C	D	E	F	G
1410 D	2660	2285	1340	860	6040	980	1990

Model Specifications	Unit	1410 D	
			Diesel
Prime Mover	kW	195	
Theoretical Output	m <sup>3</sup> /hr	94/63	
Del. Cylinder Diameter	mm	200	
Del. Cylinder Stroke	mm	1400	
No. of Strokes	per min	35/24	
Hydraulic Transmission	Rod Side	1:4.9	
	Head Side	1:3.3	
Concrete Pressure	bar	71/106	
Concrete Hopper Capacity	l	600	
Delivery Distance**	Horizontal	m 800	
	Vertical	m 200	

\*\*Distances to be read as either horizontal or vertical. The concrete should be pumpable & follows DIN 1045 standard.



## Largest & Longest 'S' Valve

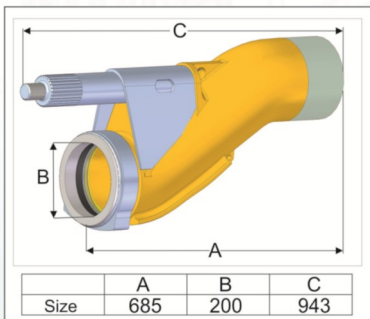

## Cylinder Diameter Comparison

**AQUARIUS**  
Concrete Pumps

Other  
Concrete Pumps

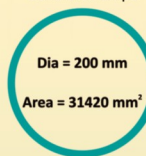

Aquarius Pump Cylinders have larger area than others by 23.5%

Performance of equipment is based on standard working conditions. Design / Specifications can be changed without prior notice.



**AQUARIUS ENGINEERS PVT. LTD.**  
Concrete Pumps, Batching Plants, Boom Pumps

'Aquarius House', Sheelavihar Colony, Off Karve Road,  
Pune 411 038. INDIA Tel.: +91 20 2544 5227 Fax: +91 20 2544 5228  
E-mail: [enquiries@aquariusengineers.biz](mailto:enquiries@aquariusengineers.biz)  
Web: [www.aquariusengineers.biz](http://www.aquariusengineers.biz)

Mfg. by: Putzmeister India Pvt. Ltd.  
190, 191, Kundaim Industrial Estate, Kundaim, Goa 403 115. India

Local Contact: