

MRH-700DSCB (700kg)

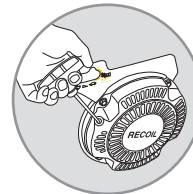

● Recoil Start (MRH-700DSCB/700GS)

MRH-700GS (680kg)



MRH Specifications

model	weight (kg)	dimensions (mm)	drum size (mm)	vibrating frequency Hz (V.P.M.)	centrifugal force kN (kgf)	traveling speed (km/h)	max.limited gradeability (%)	water tank (lits)	power source kW (PS)
MRH-501DS (water cooled)	530	H : 1,195 W: 617 L : 2,265	dia : 355 width : 575	55 (3,300)	10.0 (1,020)	0-3	35	30	Kubota EA330 diesel (electric start) max. output 4.6 (6.3)
MRH-700DSB (water cooled)	728	H : 1,170 W: 692 L : 2,670	dia : 406 width : 650		23.5 (2,400)				Yanmar TF70V diesel (electric start) max. output 5.5 (7.5)
MRH-700DSCB (air cooled)	700				Yanmar L100N diesel (electric start) max. output 7.4 (10.0)				
MRH-700GS	680								Honda GX390 gasoline (electric start) max. output 8.7 (11.8)

Vibration Roller

- Mikasa's original strainer and plastic water tank prevents the sprinkler pipes from clogging.
- The durability of travel motor have been improved.
- Rubber Bumper is equipped as standard to absorb the impact from frontal collisions lessening the damage to the machine.
- Head LED Light suited nighttime work is equipped as standard.

MRH-601DS (551kg)

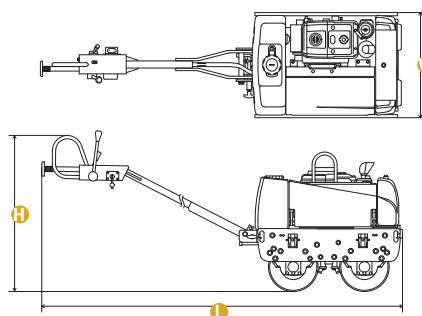

● One-Touch Center Cover



● Head LED Light and Rubber Bumper

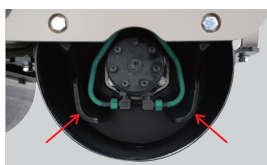

● Hydraulic Pipe Guard

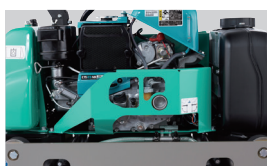

● Engine Guard



● Handbrake



● Drum Stopper



● Deadman Brake



● Buzzer and Light Switch



● Vibration Switch



● Hour Meter

MRH Specifications

model	weight (kg)	dimensions (mm)	drum size (mm)	vibrating frequency Hz (V.P.M.)	centrifugal force kN (kgf)	traveling speed (km/h)	max.limited gradeability (%)	water tank (lits)	power source kW (PS)
MRH-601DS (water cooled)	551	H : 1,195 W : 692 L : 2,265	dia : 355 width : 650	55 (3,300)	10.8 (1,100)	0-3	35	30	Kubota EA330 diesel (electric start) max. output 4.6 (6.3)